



# LED Light Sheet Snap Frames

Slim LED light boxes at just 25mm deep, created to bespoke specification

Product Brochure

## Any size light box up to a maximum 1000mm x 3000mm



Delivering bright, even illumination with no spotting or dark patches, Applelec's super slim LED snap frames are created with a depth of 25mm.

Designed for use with translucent graphics and featuring illumination from LED Light Sheet in a made-to-measure frame, Applelec's light boxes are available at a maximum size of 1000mm x 3000mm. At larger sizes, the 25mm depth is not compromised as supportive materials are built into the structure of the light box to provide suitable rigidity according to the requirements of the installation.

With everything created in-house, including the LED Light Sheet panels which illuminate the light boxes, Applelec can deliver rapid turnaround times for single or multiple bespoke light box projects.



Suitable for internal applications or created with an IP67 rating for exterior projects, LED light boxes are constructed in aluminium which is precisely cut on an aluminium chop saw. Featuring a silver anodised coating as standard, frames can be painted to any RAL or British Standard reference or can be finished with a bright polish where frames are hand polished to a high gloss shine.

Additional screws may be added to frame corners to create tamper-proof systems.

### Key Features

- Slim 25mm deep frame
- IP67 rating available
- Maximum frame size 1000mm x 3000mm
- Silver anodised, painted or bright polished finishes
- Bright, even illumination with LED Light Sheet

## Construction

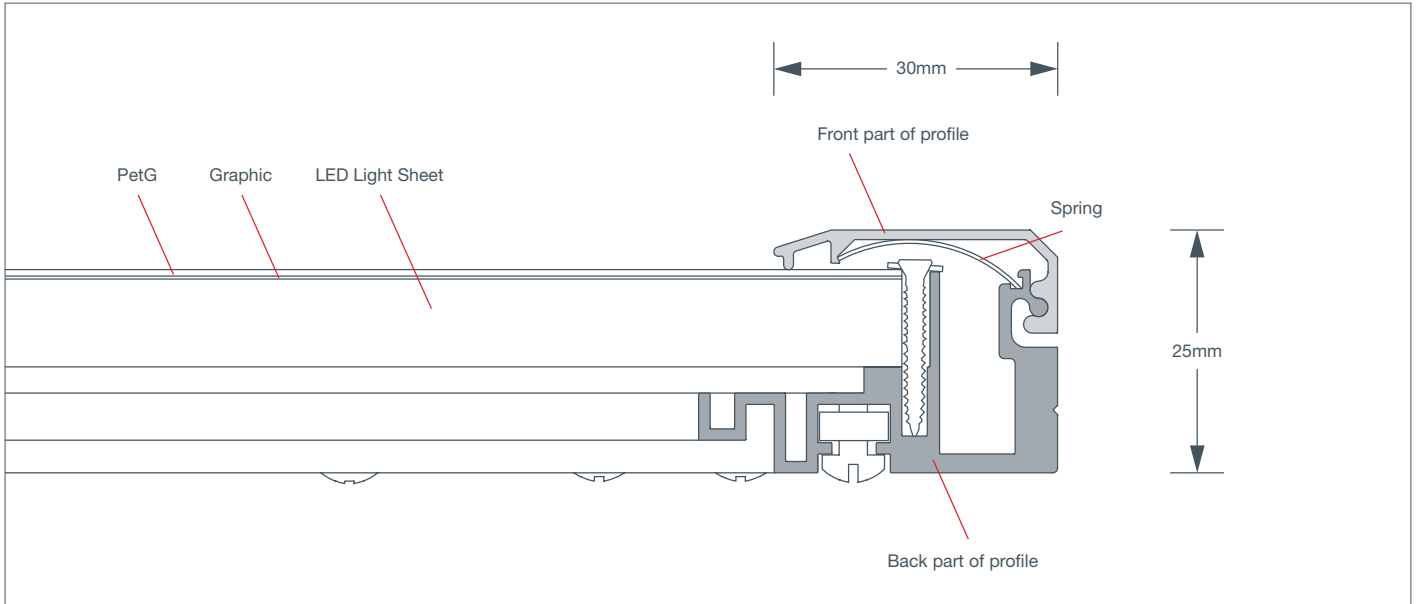

## Dimensions

The following measurements should be used to calculate the required external frame size and graphic. Please note the resulting graphic visual area when designing and sizing artwork.

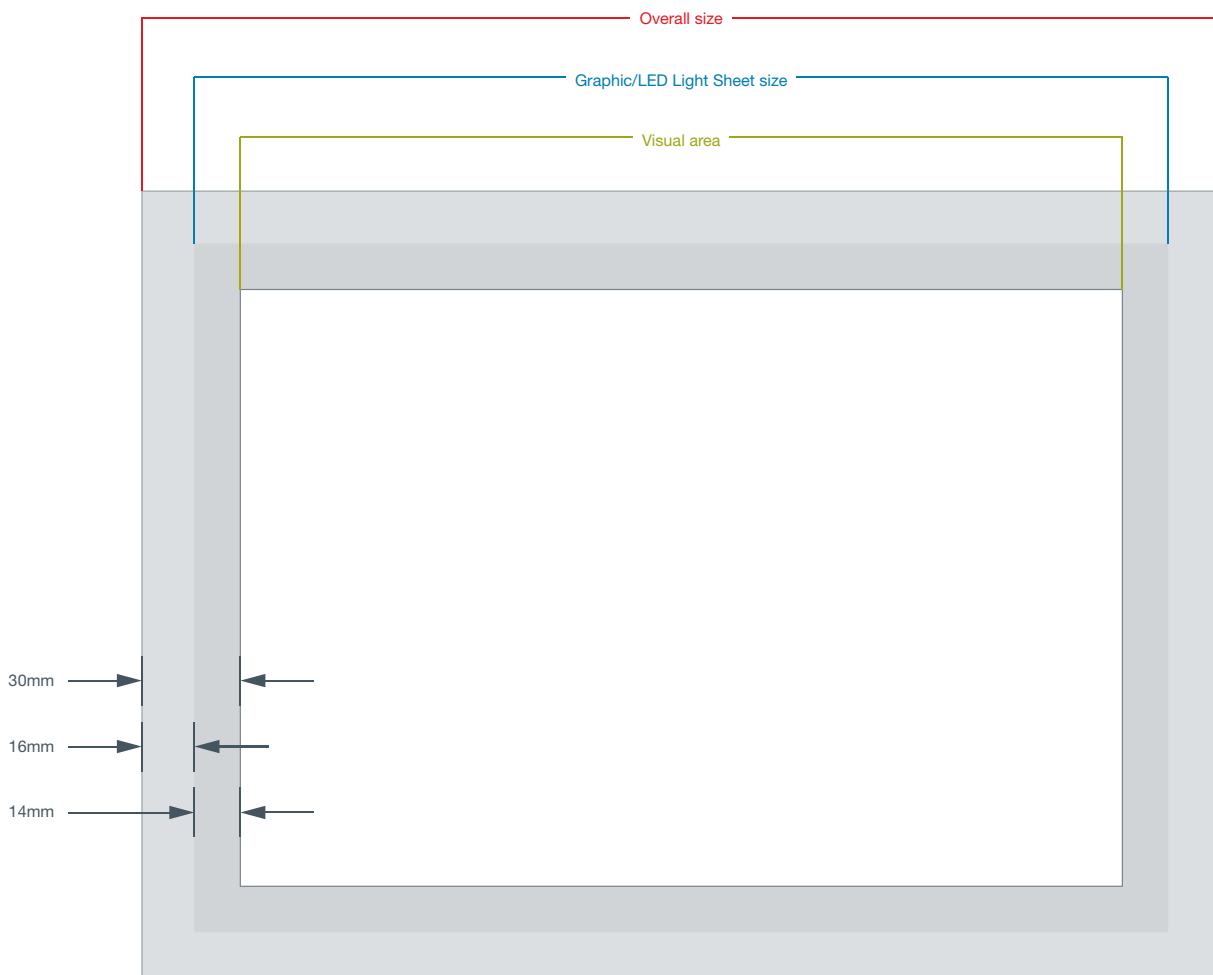

## Finishes



Silver anodised  
Standard frame finish



Painted  
Satin, matt or gloss



Bright Polished  
Hand finished to a high gloss shine

## Fixings

LED Light Sheet Snap Frames can be fixed using a variety of methods. For wall mounted frames, drilling through the largest part of the extrusion enables the frame to be fitted flush to a surface. Please note that the number of holes required may vary according to the size of the frame with 500mm intervals recommended for larger frames. Pre-drilled holes are possible under consultation with the Applelec sales team.

Dependent on frame weight, suspended and floor-to-ceiling fixing systems are possible using Applelec's Premium INOX fixings. Each fixing can accommodate a maximum of 10 kilos and can be secured to the corner of the frame. In all instances it is recommended that fixing solutions are discussed with an Applelec sales advisor prior to use and where required customer testing is undertaken.

### Wall mount diagram

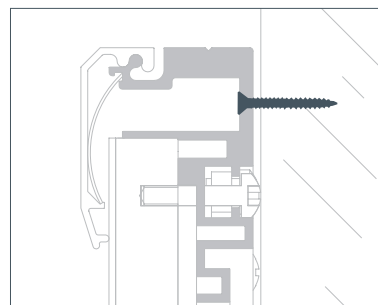

For more information on Applelec's products, please get in touch:

 01274 774 477

 [sales@applelec.co.uk](mailto:sales@applelec.co.uk)

 [www.applelec.co.uk](http://www.applelec.co.uk)

---

 **Postal address:**

Applelec  
Unit 1, Wharfedale Business Park  
Shetcliffe Lane  
Bradford  
West Yorkshire  
BD4 9RW